

LOAD CAPACITY
350Kg

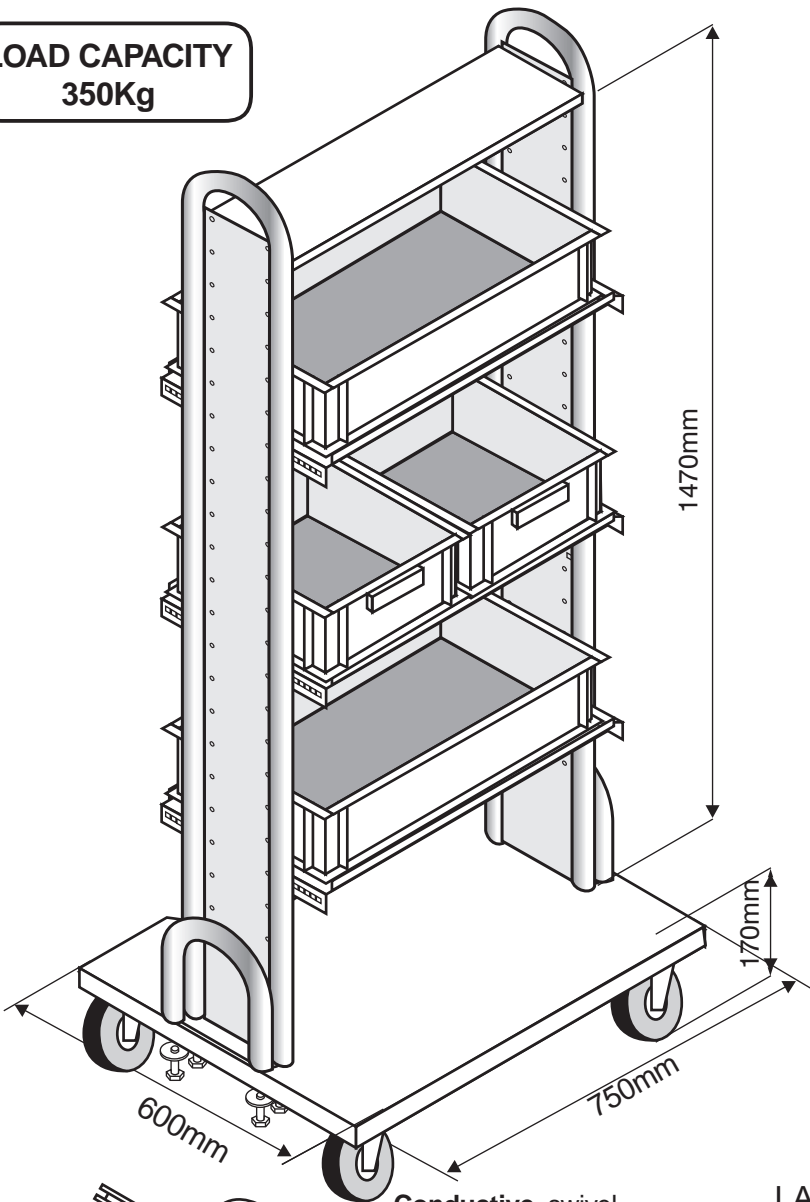

CHARIOTTE

NEWBOX HANDLING

CHARIOTTE conductive trolleys are ideal for efficient handling of tote boxes, circuit board carriers, cabinets and other parts handling containers.

The basic unit consist of two lateral support posts on a stable, wide based assembly.

Steel shelves are adjustable in height, depth and tilt angle.

P370 shelf, can accomodate one EURO 600x400 or two EURO 300x400 boxes.

Conductive swivel castors $\Phi 125\text{mm}$ (2 with brake)

LATERAL POST WITH HANDLE

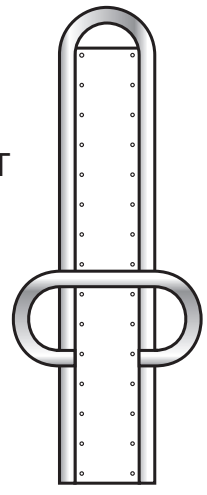

PART LIST

- 8100.050** Baseplate with conductive castors F 125mm
- 8100.054** Single Stainless Steel lateral support post (30 M6 screw and floating nuts included) (note : Lateral support posts are 2 each trolley)
- 8100.055** Single lateral post with Handle
- 8100.058** Upper tie (optional)
- 8100.065** SHELF P370 (dim.370x630mm)

Example with angled shelves and with horizontal offset

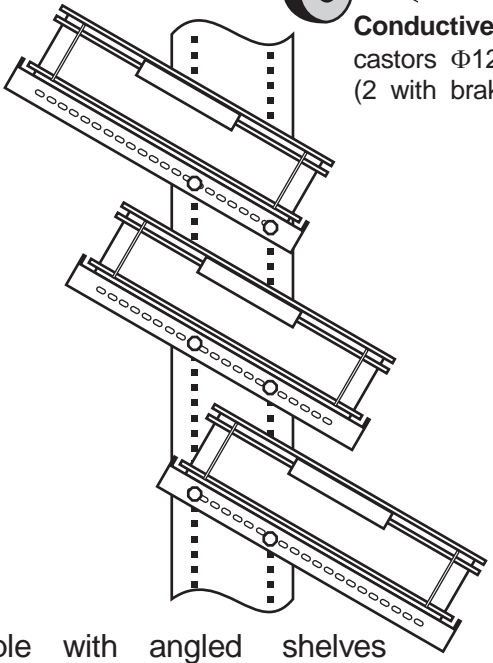

Typical resistance to Ground
 $R_G = 10^3 \text{ to } 10^5 \Omega$

Compliance with IEC 61340-5-1