

**LOAD CAPACITY**  
350Kg

## CHARIOTTE

### SMD REEL HOLDER (2 sizes available)

CHARIOTTE reel holder is designed to prepare and transport the SMD reels to the assembly area, and mainly to make the replacement of empty reels on the automatic machines.

The capacity of the trolley is 4 shelves for reel size 330mm and 5 shelves for reel size 220mm.

Steel shelves are adjustable in height, the mobile dividers help to compartmentalize the reels.  
Every shelf is provided with labels.

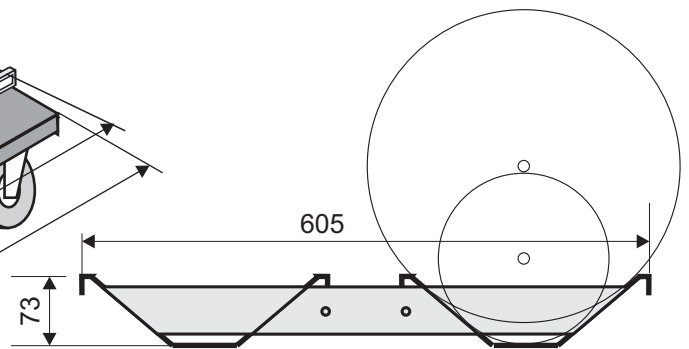
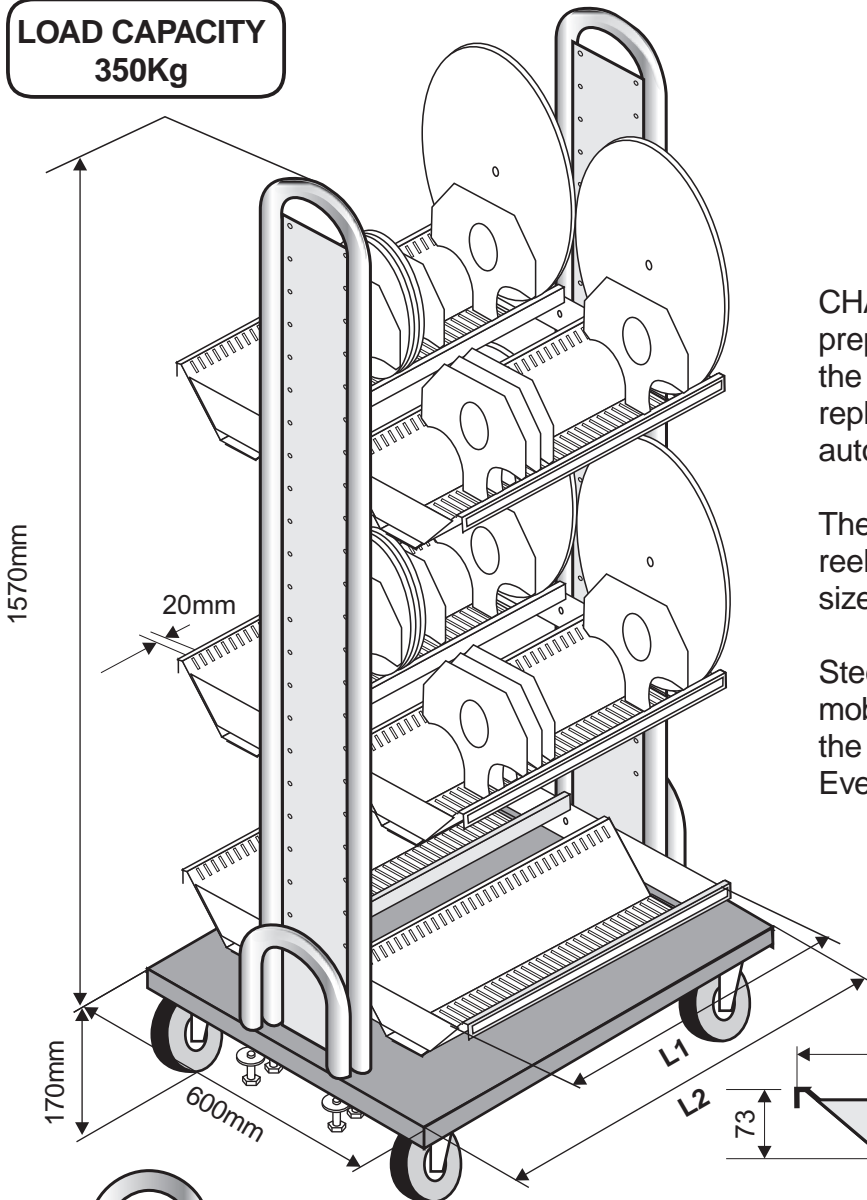

**DOUBLE SHELF**

**Conductive** swivel castors  $\Phi 125\text{mm}$   
(2 with brake)

**8100.075P**  
**DIVIDER**  
conductive plastic

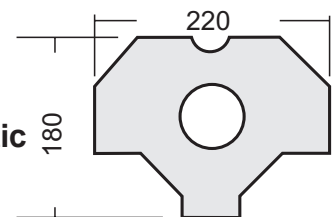

#### PART LIST

- 8100.050** Stainless steel baseplate with castors 600x760(L2)mm
- 8100.049** Stainless steel baseplate with castors 600x1130(L2)mm
- 8100.054** Single Stainless Steel lateral support post (30 M6 screw and nuts included)  
(note : Lateral support posts are 2 each trolley)
- 8100.055** Single lateral post with Handle
- 8100.073** Double shelf for SMD reel support L1 = 630mm
- 8100.074** Double shelf for SMD reel support L1 = 1000mm
- 8100.075** Divider for SMD reel

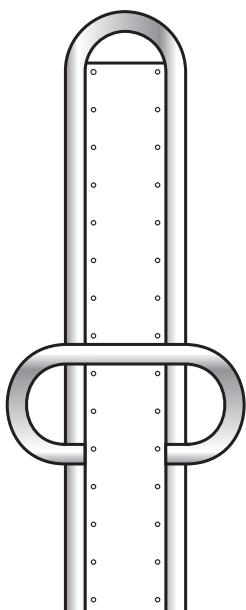

**LATERAL POST WITH HANDLE**