

APP Tools for EXPERT 10.6 Rework Systems

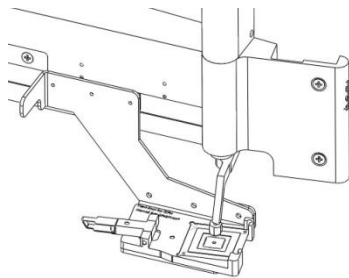

SF64.0520
Print Tool with squeegee

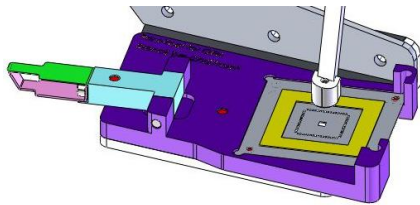
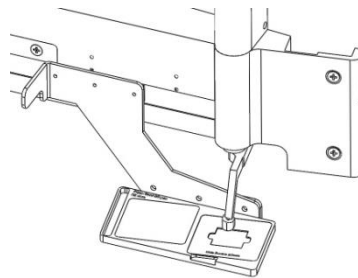
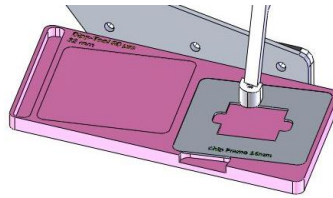

SF64.0525, SF64.0526, SF64.0527
Dip Tool 32 x 0,08 mm with squeegee
Dip Tool 32 x 0,15 mm with squeegee
Dip Tool 32 x 0,22 mm with squeegee

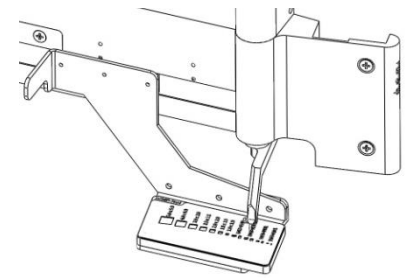
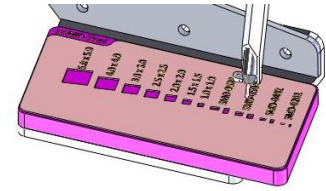

SF64.0540
μSMD Tool

A variety of application tools are available to enable rework of delicate electronic devices. Providing increased automation while simplifying operator requirements results in higher yields and increased process repeatability. Combined with the EXPERT's AVP (Automated Vision Placement) system, innovative application tools reduce overall process times and increase throughput.

Print Tool: This tool is designed to enable QFN and other delicate SMD rework. Using a stencil type fixture, solder paste or paste flux can be applied directly to a component's interconnects. Once printed, an operator secures the Print Tool housing the printed component to the EXPERT's Process Shuttle. The AVP picks a printed component from the pre-positioned Print Tool and aligns the component to prepared pads of the rework site, hands free. Reworking a QFN with the Print Tool becomes similar to typical BGAs.

Dip Tool: The application of solder flux or solder paste is simplified using the Dip-Tool. A defined quantity of flux or solder paste is precisely applied to the component by the system. The SMD is loaded onto a Component Nest supported by the Process Shuttle. Once picked by the system, the component is then dipped into and removed from the Dip Tool, aligned and then placed by AVP to prepared pads of the rework site, hands free.

μSMD Tool: Even the smallest SMD component is now able to be handled with the EXPERT 10.6 rework system when using the μSMD Nest. Loading of small components can even be done off-line. The pre-loaded μSMD Nest is then installed onto the Process Shuttle awaiting pick-up by the system.

Feature Availability







- Application Tools may require component specific tooling such as sliders, masks and frames. Standard tooling is readily available from MARTIN. Also available is custom tooling to meet your rework needs.

Technical Data

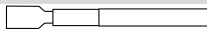

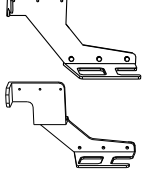



Print Tool (size range)	1,5 x 1,5 mm ² - 20 x 120 mm ²
Dip Tool (size range BGA)	3 x 3 mm ² - 27 x 27 mm ²
μSMD Tool (size range)	0402 - 5 x 5 mm ²

APP Tools - for EXPERT 10.6 Rework Systems

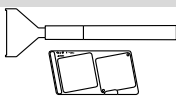
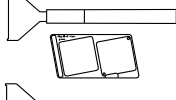
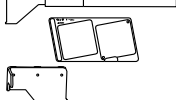

Options and Accessories – PRINT TOOL

SF64.0520	Print tool with squeegee for tool slider	
SF64.0501	Tool slider for AVP 4.1	
SF66.0501	Tool slider for AVP 4.1XL	
LWxx.xx11	Prebumping mask+frame QFN Type of standard QFN mask on request	 Maske nach Wahl
VD90.0230	Solder paste print 5ccm finepitch 4 lead free Sn96.5Ag3Cu, ROLO / 20-38µm	 5 ccm Lead free 38µm
LW10.0004	Solder paste squeegee for QFN Printer	

Options and Accessories – DIPP TOOL

SF64.0525	Dip tool 32x0.08mm with squeegee for tool slider	
SF64.0526	Dip tool 32x0.15mm with squeegee for tool slider	
SF64.0527	Dip tool 32x0.22mm with squeegee for tool slider	
SF64.0501	Tool slider for AVP 4.1	
SF66.0501	Tool slider for AVP 4.1XL	
HT00.0116	Flux Creme lead free 5ccm (appr. 5g), 0506 MA, no clean, RELO	 Lead free
HT00.0117	Flux Creme lead free 100g 0506 MA, no clean, RELO	 100g Leadfree
LW10.0005	Squeegee for dipp tool	

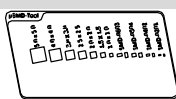
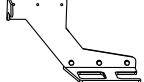
Options and Accessories – µSMD TOOL

SF64.0540	µSMD tool for tool slider	
SF64.0501	Tool slider for AVP 4.1	
SF66.0501	Tool slider for AVP 4.1XL	

Further units and consumables under www.martin-smt.de